

**ALPHA**  
CRANE & FORKLIFTS  
[www.alphacrane.in](http://www.alphacrane.in)

# FORKLIFTS

## Forklifts

Capacity : 6, 8, 10 tons

High Performance & rugged  
Forklift Trucks.

**ACE** INDIA'S NO. 1  
MOBILE & TOWER CRANE CO.



*Nothing beats an* **ACE**



## SPECIFICATIONS

| Model  | Unit                | AF 60D               | AF 80D                | AF 100D         |                  |
|--|---------------------|----------------------|-----------------------|-----------------|------------------|
| Load Capacity                                | Kg                  | 6000                 | 8000                  | 10000           |                  |
| Power  |                     | Diesel               |                       |                 |                  |
| Tyres  | Front / Rear        | Pneumatic            |                       |                 |                  |
| Wheel (s)                                    | Front / Rear        | Nos. 4 / 2           |                       |                 |                  |
| Fork Height (std.)                           | mm                  | 3000                 |                       |                 |                  |
| Fork Size (LxWxT)                            | mm                  | 1220 x 150 x 60      | 1220 x 150 x 80       | 1220 x 175 x 80 |                  |
| Tilt Angle $\alpha(\alpha-\beta)$            | degree              | 6°-12°               |                       |                 |                  |
| Overall length                               | mm                  | 4770                 | 4860                  | 5390            |                  |
| Overall Width                                | mm                  | 1995                 | 2025                  | 2245            |                  |
| Overall Lowered Height                       | mm                  | 2500                 |                       | 2850            |                  |
| Overall Raised Height (* With load backrest) | mm                  | 4380*                |                       | 4320            |                  |
| Overhead Guard Clearance (from face of seat) | mm                  | 1100                 |                       | 1120            |                  |
| Turning Radius (Outside)                     | mm                  | 3300                 | 3400                  | 3900            |                  |
| Speed (s)                                    | Travel (F/ R)       | With/Without Load    | Km/h                  | 27              | 30               |
|  |                     | Lifting              | With Load             | mm/s            | 395              |
|  | Without Load        |                      | mm/s                  | 420             | 350              |
|  | Lowering            | With Load            | mm/s                  | 600             |                  |
|  |                     | Without Load         | mm/s                  | 300             |                  |
| Gradeability                                 | With / Without Load | %                    | 20                    | 18              |                  |
| Total Weight                                 |                     | Kg                   | 9040                  | 10495           | 12510            |
| Tyre Sizes                                   | Front               |                      | 8.25 - 15 - 14PR      |                 | 9.00 - 20 - 14PR |
|  | Rear                |                      | 8.25 - 15 - 14PR      |                 | 9.00 - 20 - 14PR |
| Wheel Base                                   |                     | mm                   | 2250                  | 2275            | 2800             |
| Tread  | Front               | mm                   | 1760                  | 1795            | 1980             |
|  | Rear                | mm                   | 1720                  |                 |                  |
| Brake (s)                                    | Service             |                      | Hydraulic-Foot Pedal  |                 |                  |
|  | Parking             |                      | Mechanical-Hand Lever |                 |                  |
| Battery                                      | Voltage / Capacity  | V / AH               | 2 x 12 / 105          |                 |                  |
| Engine                                       | Model               |                      | 6102BG                |                 |                  |
|  | Rated Horsepower    | bhp/r.p.m            | 111/2500              |                 |                  |
|  | Rated Torque        | N.m./r.p.m           | 353 / 1650            |                 |                  |
|  | Number of Cylinders |                      | 6                     |                 |                  |
|  | Displacement        | Ltrs.                | 5.785                 |                 |                  |
|  | Fuel Tank Capacity  | Ltrs.                | 140                   |                 |                  |
| Transmission                                 | Number of Speeds    |                      | 2/2 Power Shift       |                 |                  |
| Operating Pressure                           | For Attachment      | Kg / cm <sup>2</sup> | 200                   |                 |                  |

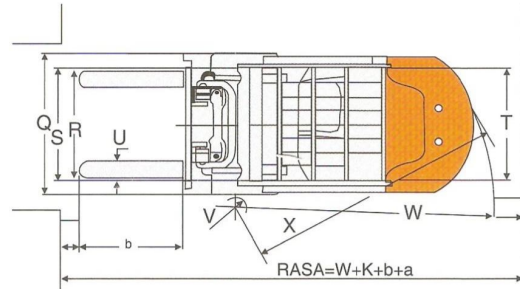
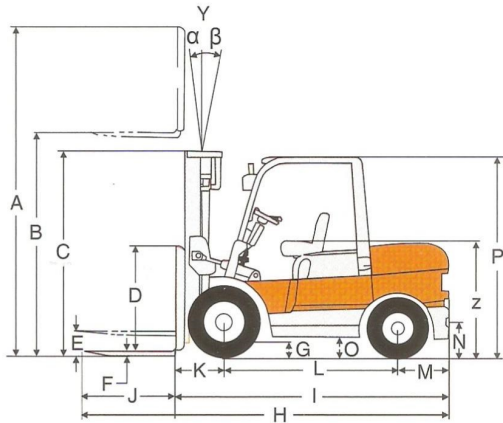

### STANDARD DIMENSIONS

| MODEL  | AF 60D   | AF 80D | AF 100D  |
|--|----------|--------|----------|
| A Overall Height fork raised (*with Load Back Rest)) | 4380*    |        | 4320     |
| B Max fork Height                                    | 3000     |        |          |
| C Overall Height fork Lowered                        | 2500     |        | 2850     |
| D Backrest Height                                    | 1380     |        | N/A      |
| E Free Lift  | 150      |        | 210      |
| F Fork Thickness                                     | 60       | 80     |          |
| G Min clearance (Bottom of mast)                     | 170      |        | 250      |
| H Overall Length (with forks)                        | 4770     | 4860   | 5390     |
| I Overall Length (without forks)                     | 3550     | 3740   | 4170     |
| J Fork Length  | 1220     |        |          |
| K Fork Overhang                                      | 590      |        | 720      |
| L Wheel base   | 2250     | 2275   | 2800     |
| M Rear Overhang                                      | 733      |        | 740      |
| N Coupler Height                                     | 450      |        | 520      |
| O Ground clearance (Bottom of Frame)                 | 240      |        | 330      |
| P Overall Height (overhead guard)                    | 2450     |        | 2585     |
| Q Overall width                                      | 1995     | 2025   | 2245     |
| R Lateral fork Adjustment                            | 300-1835 |        | 400-2140 |
| S Tread (Front)                                      | 1760     |        | 1910     |
| T Tread (Rear)                                       | 1720     |        |          |
| U Fork width   | 150      |        | 175      |
| V Inside Turning radius                              | 1600     |        | 2100     |
| W Outside Turning radius                             | 3300     | 3400   | 3900     |
| X Min. Intersecting aisle                            | 3000     | 3040   | 3540     |
| Y Tilting angles ( $\alpha$ - $\beta$ )              | 6°-12°   |        |          |
| Z Seat Height from Ground level                      | 1225     |        | 1370     |



# FORKLIFTS

## Forklifts

### STANDARD EQUIPMENT

- Wide view mast
- Load backrest for AF60D & AF80D
- Standard forks
- Power steering
- Retaining rollers
- Overhead guard
- Standard seat (Adjustable)
- Drawbar pin
- Air cleaner
- Parking brake lever
- Lift, tilt levers
- Dipstick for TC oil
- Return hydraulic filter
- TC oil filter
- Lift Circuit cut-off valve
- Overhead air intake
- Radiator reservoir
- Tilt adjustable steering wheel
- Turn indicator Lights
- Hour meter
- Water temperature meter
- Fuel meter
- Engine oil pressure warning indicator
- Electric charge indicator
- Halogen head lights
- Rear combination lights
- Rear view mirrors
- Reverse Buzzer
- Electric horn
- Neutral safety switch (TC)
- Rubber floor mat
- Tool kit
- Front dual wheels

### OPTIONAL EQUIPMENT

- Spark arrester
- Solid tyres
- Fire extinguisher

### OPTIONAL ATTACHMENTS

- Different Mast type
- Fork extensions
- Fork positioner
- Crane attachment
- Ram attachment
- Container handling model
- Container stuffing model

### LOAD CHART

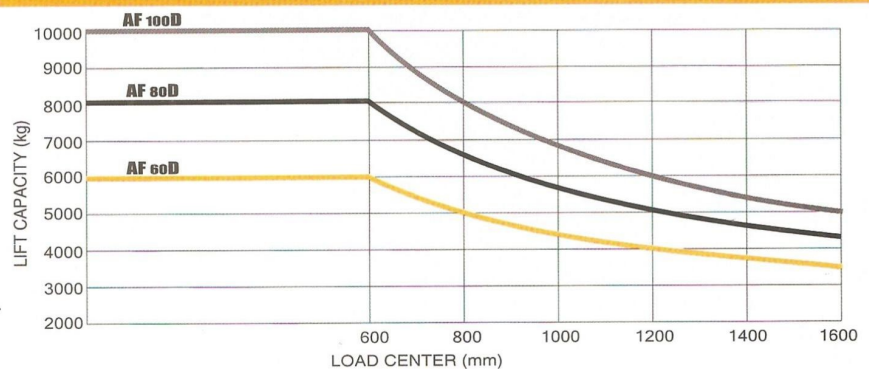

### Model AF80D (Empty Container Handler)

- Robust design to handle 3 high stacking (6 mtr lift height)
- Fitted with wide carriage and 2400 mm long forks for stability